

**LOW VOLTAGE PARALLEL 64K (8K x 8) EEPROM
WITH SOFTWARE DATA PROTECTION**

- FAST ACCESS TIME: 200ns
- SINGLE LOW VOLTAGE OPERATION
- LOW POWER CONSUMPTION
- FAST WRITE CYCLE:
 - 64 Bytes Page Write Operation
 - Byte or Page Write Cycle: 3ms Max
- ENHANCED END OF WRITE DETECTION:
 - Ready/Busy Open Drain Output (only on the M28LV64)
 - Data Polling
 - Toggle Bit
- PAGE LOAD TIMER STATUS BIT
- HIGH RELIABILITY SINGLE POLYSILICON, CMOS TECHNOLOGY:
 - Endurance >100,000 Erase/Write Cycles
 - Data Retention >40 Years
- JEDEC APPROVED BYTEWIDE PIN OUT
- SOFTWARE DATA PROTECTION

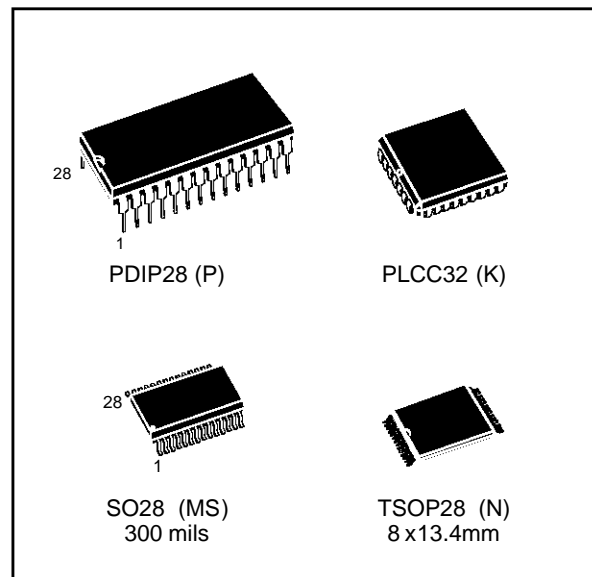

DESCRIPTION

The M28LV64 is an 8K x 8 low power Parallel EEPROM fabricated with SGS-THOMSON proprietary single polysilicon CMOS technology. The device offers fast access time with low power dissipation and requires a 2.7V to 3.6V power supply.

Table 1. Signal Names

A0 - A12	Address Input
DQ0 - DQ7	Data Input / Output
\bar{W}	Write Enable
\bar{E}	Chip Enable
\bar{G}	Output Enable
\bar{RB}	Ready / Busy
V _{CC}	Supply Voltage
V _{SS}	Ground

Figure 1. Logic Diagram

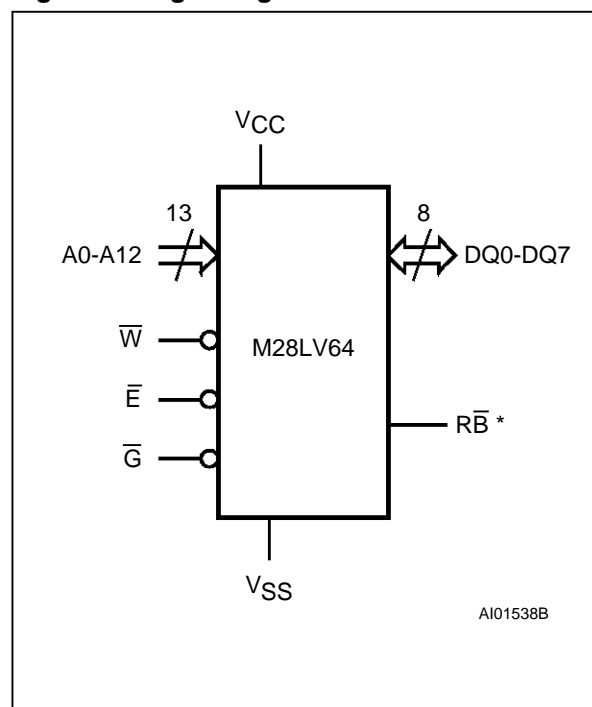

Note: * \bar{RB} function is only available on the M28LV64.

Figure 2A. DIP Pin Connections

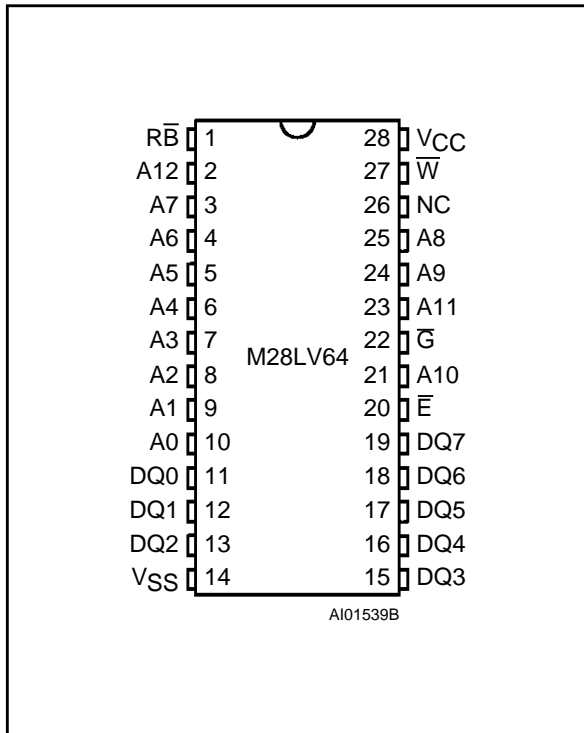

Warning: NC = Not Connected.

Figure 2B. LCC Pin Connections

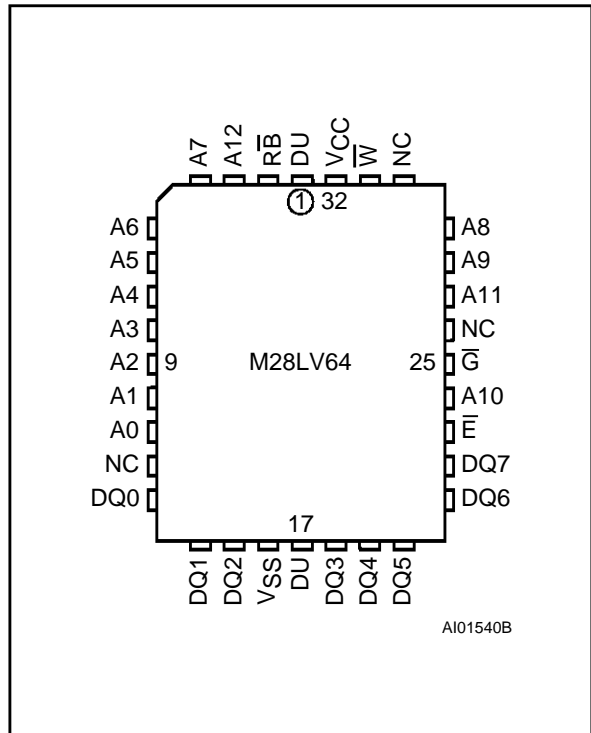

Warning: NC = Not Connected, DU = Don't Use

Figure 2C. SO Pin Connections

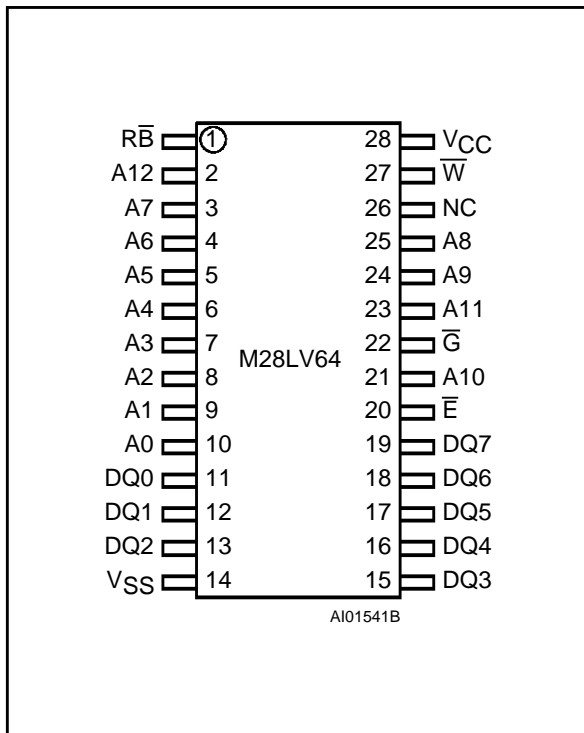

Warning: NC = Not Connected.

Figure 2D. TSOP Pin Connections

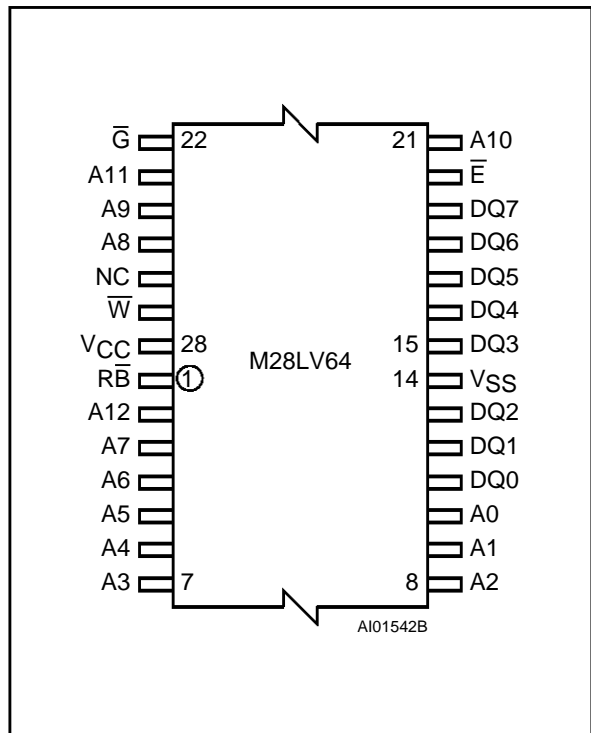

Warning: NC = Not Connected.

Table 2. Absolute Maximum Ratings ⁽¹⁾

Symbol	Parameter	Value	Unit
T _A	Ambient Operating Temperature	- 40 to 85	°C
T _{STG}	Storage Temperature Range	- 65 to 150	°C
V _{CC}	Supply Voltage	- 0.3 to 6.5	V
V _{IO}	Input/Output Voltage	- 0.3 to V _{CC} +0.6	V
V _I	Input Voltage	- 0.3 to 6.5	V
V _{ESD}	Electrostatic Discharge Voltage (Human Body model) ⁽²⁾	4000	V

Notes: 1. Except for the rating "Operating Temperature Range", stresses above those listed in the Table "Absolute Maximum Ratings" may cause permanent damage to the device. These are stress ratings only and operation of the device at these or any other conditions above those indicated in the Operating sections of this specification is not implied. Exposure to Absolute Maximum Rating conditions for extended periods may affect device reliability. Refer also to the SGS-THOMSON SURE Program and other relevant quality documents.

2. 100pF through 1500Ω; MIL-STD-883C, 3015.7

Figure 3. Block Diagram

Table 3. Operating Modes ⁽¹⁾

Mode	\bar{E}	\bar{G}	\bar{W}	DQ0 - DQ7
Standby	1	X	X	Hi-Z
Output Disable	X	1	X	Hi-Z
Write Disable	X	X	1	Hi-Z
Read	0	0	1	Data Out
Write	0	1	0	Data In

Note: 1. 0 = V_{IL} ; 1 = V_{IH} ; X = V_{IL} or V_{IH} .

DESCRIPTION (cont'd)

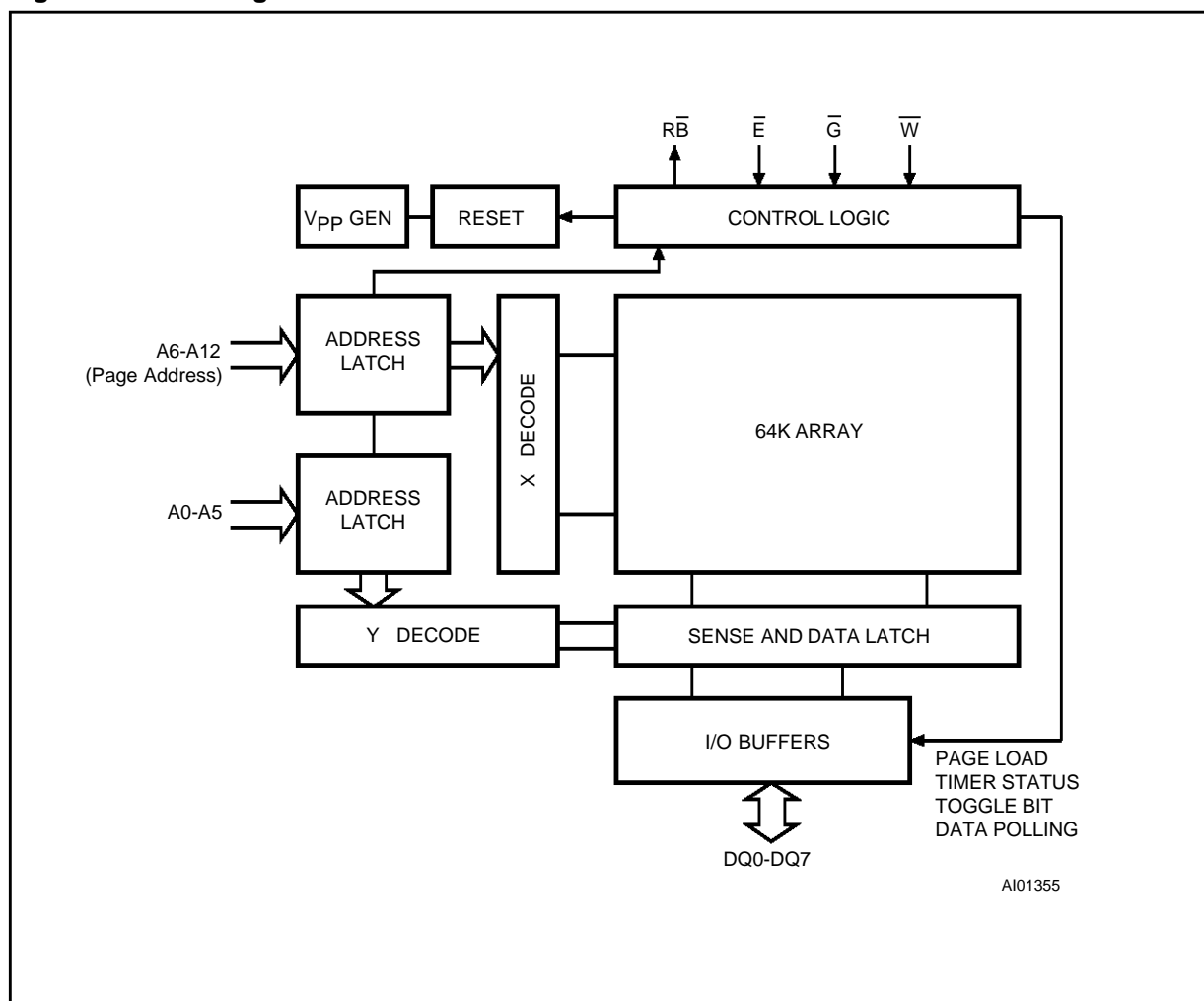
The M28LV64 outputs the Ready/Busy write status, the M28LV64-aaaX (aaa = access time) has no Ready/Busy status and the relevant $\bar{R}\bar{B}$ pin is Not Connected (NC). The circuit has been designed to offer a flexible microcontroller interface featuring both hardware and software handshaking with Ready/Busy, Data Polling and Toggle Bit. The M28LV64 supports 64 byte page write operation. A Software Data Protection (SDP) is also possible using the standard JEDEC algorithm.

PIN DESCRIPTION

Addresses (A0-A12). The address inputs select an 8-bit memory location during a read or write operation.

Chip Enable (\bar{E}). The chip enable input must be low to enable all read/write operations. When Chip Enable is high, power consumption is reduced.

Output Enable (\bar{G}). The Output Enable input controls the data output buffers and is used to initiate read operations.

Data In/ Out (DQ0 - DQ7). Data is written to or read from the M28LV64 through the I/O pins.

Write Enable (\bar{W}). The Write Enable input controls the writing of data to the M28LV64.

Ready/Busy ($\bar{R}\bar{B}$). Ready/Busy is an open drain output that can be used to detect the end of the internal write cycle (this function applies only to the M28LV64).

OPERATION

In order to prevent data corruption and inadvertent write operations an internal V_{CC} comparator inhibits Write operation if V_{CC} is below V_{WI} (see Table 6). Access to the memory in write mode is allowed after a power-up as specified in Table 6.

Read

The M28LV64 is accessed like a static RAM. When \bar{E} and \bar{G} are low with \bar{W} high, the data addressed is presented on the I/O pins. The I/O pins are high impedance when either \bar{G} or \bar{E} is high.

Write

Write operations are initiated when both \bar{W} and \bar{E} are low and \bar{G} is high. The M28LV64 supports both \bar{E} and \bar{W} controlled write cycles. The Address is latched by the falling edge of \bar{E} or \bar{W} which ever occurs last and the Data on the rising edge of \bar{E} or \bar{W} which ever occurs first. Once initiated the write operation is internally timed until completion.

Page Write

Page write allows up to 64 bytes to be consecutively latched into the memory prior to initiating a programming cycle. All bytes must be located in a single page address, that is A6-A12 must be the same for all bytes. The page write can be initiated during any byte write operation.

Following the first byte write instruction the host may send another address and data with a minimum data transfer rate of t_{WHWH} (see Figure 13). If a transition of \bar{E} or \bar{W} is not detected within t_{WHWH} the internal programming cycle will start.

Microcontroller Control Interface

The M28LV64 provides two write operation status bits and one status pin that can be used to minimize the system write cycle. These signals are available on the I/O port bits DQ7 or DQ6 of the memory during programming cycle only, or as the \overline{RB} signal on a separate pin.

Figure 4. Status Bit Assignment

DQ7	DQ6	DQ5	DQ4	DQ3	DQ2	DQ1	DQ0
DP	TB	PLTS	Hi-Z	Hi-Z	Hi-Z	Hi-Z	Hi-Z

DP = Data Polling
TB = Toggle Bit
PLTS = Page Load Timer Status

Data Polling bit (DQ7). During the internal write cycle, any attempt to read the last byte written will produce on DQ7 the complementary value of the previously latched bit. Once the write cycle is finished the true logic value appears on DQ7 in the read cycle.

Toggle bit (DQ6). The M28LV64 offers another way for determining when the internal write cycle is completed. During the internal Erase/Write cycle, DQ6 will toggle from "0" to "1" and "1" to "0" (the first read value is "0") on subsequent attempts to read the memory. When the internal cycle is completed the toggling will stop and the device will be accessible for a new Read or Write operation.

Page Load Timer Status bit (DQ5). In the Page Write mode data may be latched by \overline{E} or \overline{W} up to 100 μ s after the previous byte. Up to 64 bytes may be input. The Data output (DQ5) indicates the status of the internal Page Load Timer. DQ5 may

be read by asserting Output Enable Low (t_{PLTS}). DQ5 Low indicates the timer is running, High indicates time-out after which the write cycle will start and no new data may be input.

Ready/Busy pin (available only on the M28LV64). The \overline{RB} pin provides a signal at its open drain output which is low during the erase/write cycle, but which is released at the completion of the programming cycle.

Software Data Protection

The M28LV64 offers a software controlled write protection facility that allows the user to inhibit all write modes to the device including the Chip Erase instruction. This can be useful in protecting the memory from inadvertent write cycles that may occur due to uncontrolled bus conditions.

The M28LV64 is shipped as standard in the "unprotected" state meaning that the memory contents can be changed as required by the user. After the Software Data Protection enable algorithm is issued, the device enters the "Protect Mode" of operation where no further write commands have any effect on the memory contents. The device remains in this mode until a valid Software Data Protection (SDP) disable sequence is received whereby the device reverts to its "unprotected" state. The Software Data Protection is fully non-volatile and is not changed by power on/off sequences.

To enable the Software Data Protection (SDP) the device requires the user to write (with a Page Write) three specific data bytes to three specific memory locations as per Figure 5. Similarly to disable the Software Data Protection the user has to write specific data bytes into six different locations as per Figure 6 (with a Page Write). This complex series ensures that the user will never enable or disable the Software Data Protection accidentally.

Figure 5. Software Data Protection Enable Algorithm and Memory Write

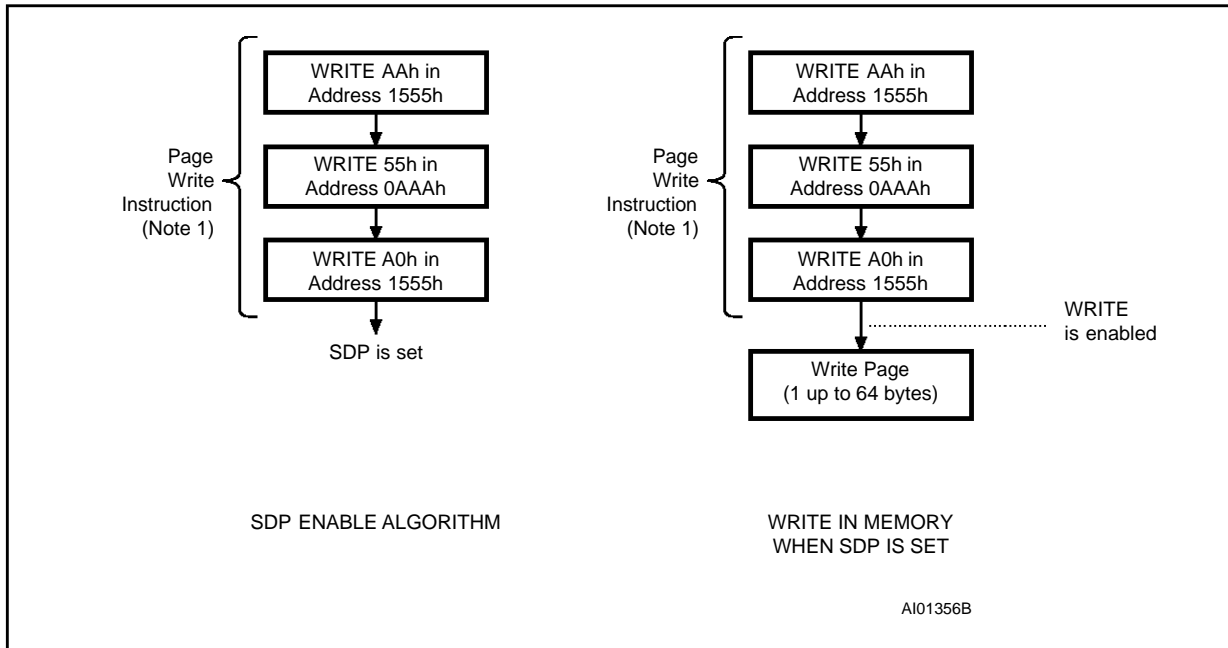

Note: 1. MSB Address bits (A6 to A12) differ during these specific Page Write operations.

Figure 6. Software Data Protection Disable Algorithm

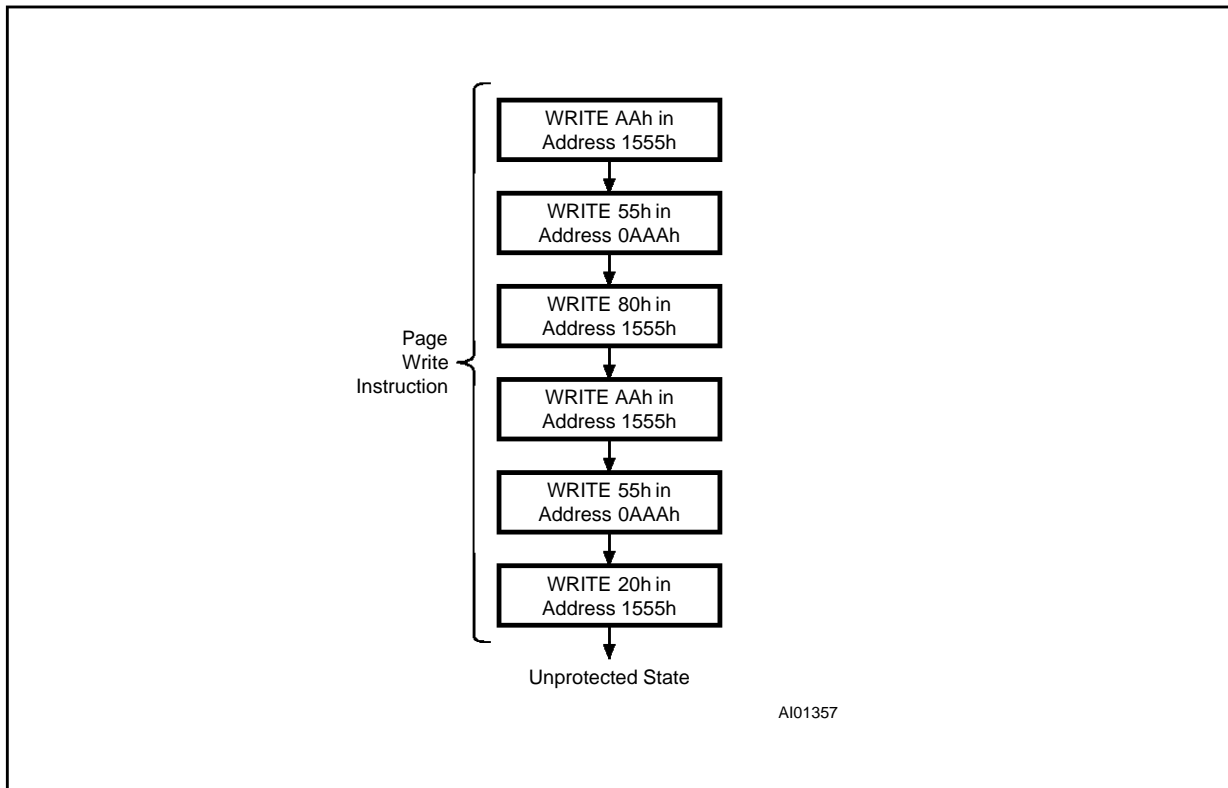

AC MEASUREMENT CONDITIONS

Input Rise and Fall Times	$\leq 20\text{ns}$
Input Pulse Voltages	0V to $V_{CC} - 0.3\text{V}$
Input and Output Timing Ref. Voltages	1.5V

Note that Output Hi-Z is defined as the point where data is no longer driven.

Figure 7. AC Testing Input Output Waveforms

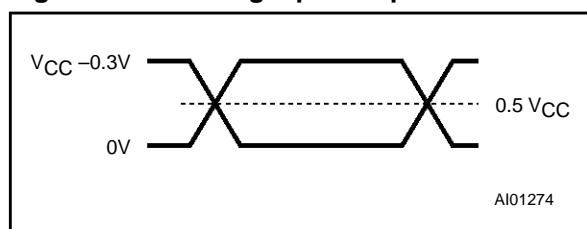

Figure 8. AC Testing Equivalent Load Circuit

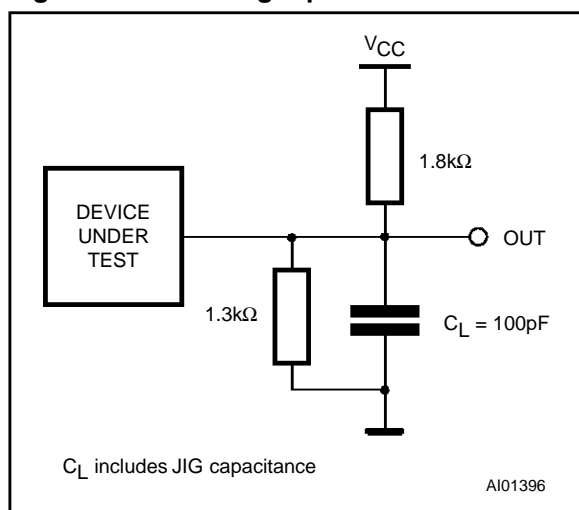

Table 4. Capacitance⁽¹⁾ ($T_A = 25^\circ\text{C}$, $f = 1\text{MHz}$)

Symbol	Parameter	Test Condition	Min	Max	Unit
C_{IN}	Input Capacitance	$V_{IN} = 0\text{V}$		6	pF
C_{OUT}	Output Capacitance	$V_{OUT} = 0\text{V}$		12	pF

Note: 1. Sampled only, not 100% tested.

Table 5. Read Mode DC Characteristics

($T_A = 0$ to 70°C or -40 to 85°C ; $V_{CC} = 2.7\text{V}$ to 3.6V)

Symbol	Parameter	Test Condition	Min	Max	Unit
I_{LI}	Input Leakage Current	$0\text{V} \leq V_{IN} \leq V_{CC}$		1019	μA
I_{LO}	Output Leakage Current	$0\text{V} \leq V_{IN} \leq V_{CC}$		10	μA
$I_{CC}^{(1)}$	Supply Current (CMOS inputs)	$\bar{E} = V_{IL}, \bar{G} = V_{IL}, f = 5\text{MHz}, V_{CC} = 3.3\text{V}$		8	mA
		$\bar{E} = V_{IL}, \bar{G} = V_{IL}, f = 5\text{MHz}, V_{CC} = 3.6\text{V}$		10	mA
$I_{CC2}^{(1)}$	Supply Current (Standby) CMOS	$\bar{E} > V_{CC} - 0.3\text{V}$		20	μA
V_{IL}	Input Low Voltage		-0.3	0.6	V
V_{IH}	Input High Voltage		2	$V_{CC} + 0.5$	V
V_{OL}	Output Low Voltage	$I_{OL} = 1\text{mA}$		$0.2 V_{CC}$	V
V_{OH}	Output High Voltage	$I_{OH} = 1\text{mA}$	$0.8 V_{CC}$		V

Note: 1. All I/O's open circuit.

Table 6. Power Up Timing⁽¹⁾ ($T_A = 0$ to 70°C or -40 to 85°C ; $V_{CC} = 2.7\text{V}$ to 3.6V)

Symbol	Parameter	Min	Max	Unit
t_{PUR}	Time Delay to Read Operation	1		μs
t_{PUW}	Time Delay to Write Operation (once $V_{CC} \geq 4.5\text{V}$)	15		ms
V_{WI}	Write Inhibit Threshold	1.5	2.5	V

Note: 1. Sampled only, not 100% tested.

Table 7. Read Mode AC Characteristics

($T_A = 0$ to 70°C or -40 to 85°C ; $V_{CC} = 2.7\text{V}$ to 3.6V)

Symbol	Alt	Parameter	Test Condition	M28LV64						Unit
				-200		-250		-300		
				min	max	min	max	min	max	
t_{AVQV}	t_{ACC}	Address Valid to Output Valid	$\bar{E} = V_{IL}, \bar{G} = V_{IL}$		200		250		300	ns
t_{ELQV}	t_{CE}	Chip Enable Low to Output Valid	$G = V_{IL}$		200		250		300	ns
t_{GLQV}	t_{OE}	Output Enable Low to Output Valid	$\bar{E} = V_{IL}$		100		150		150	ns
$t_{EHQZ}^{(1,2)}$	t_{DF}	Chip Enable High to Output Hi-Z	$\bar{G} = V_{IL}$	0	55	0	60	0	60	ns
$t_{GHQZ}^{(1,2)}$	t_{DF}	Output Enable High to Output Hi-Z	$\bar{E} = V_{IL}$	0	55	0	60	0	60	ns
$t_{AXQX}^{(2)}$	t_{OH}	Address Transition to Output Transition	$\bar{E} = V_{IL}, \bar{G} = V_{IL}$	0		0		0		ns

Notes: 1. Output Hi-Z is defined as the point at which data is no longer driven.
 2. Guaranteed, not 100% sampled.

Figure 9. Read Mode AC Waveforms

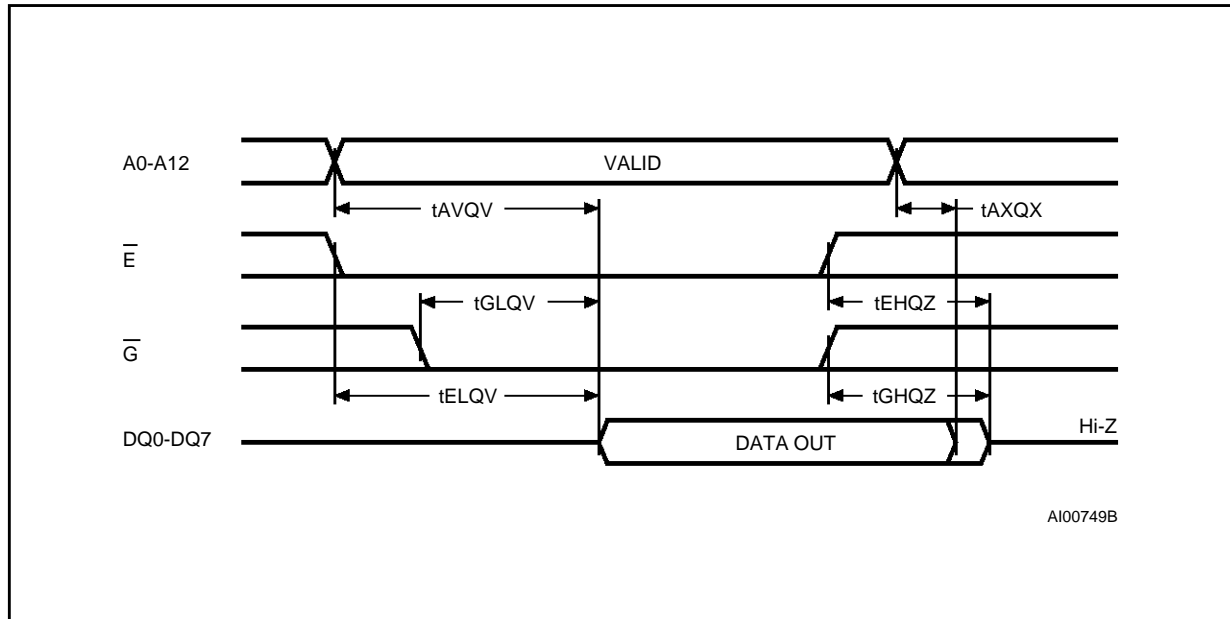

Note: Write Enable (\bar{W}) = High

Table 8. Write Mode AC Characteristics(T_A = 0 to 70°C or -40 to 85°C; V_{CC} = 2.7V to 3.6V)

Symbol	Alt	Parameter	Test Condition	Min	Max	Unit
t _{AVWL}	t _{AS}	Address Valid to Write Enable Low	$\overline{E} = V_{IL}, \overline{G} = V_{IH}$	0		ns
t _{AVEL}	t _{AS}	Address Valid to Chip Enable Low	$\overline{G} = V_{IH}, \overline{W} = V_{IL}$	0		ns
t _{ELWL}	t _{CES}	Chip Enable Low to Write Enable Low	$\overline{G} = V_{IH}$	0		ns
t _{GHWL}	t _{OES}	Output Enable High to Write Enable Low	$\overline{E} = V_{IL}$	0		ns
t _{GHEL}	t _{OES}	Output Enable High to Chip Enable Low	$\overline{W} = V_{IL}$	0		ns
t _{WLWL}	t _{WES}	Write Enable Low to Chip Enable Low	$\overline{G} = V_{IH}$	0		ns
t _{WLAX}	t _{AH}	Write Enable Low to Address Transition		100		ns
t _{ELAX}	t _{AH}	Chip Enable Low to Address Transition		100		ns
t _{WLDV}	t _{DV}	Write Enable Low to Input Valid	$\overline{E} = V_{IL}, \overline{G} = V_{IH}$		1	μs
t _{ELDV}	t _{DV}	Chip Enable Low to Input Valid	$\overline{G} = V_{IH}, \overline{W} = V_{IL}$		1	μs
t _{LELH}	t _{WP}	Chip Enable Low to Chip Enable High		100	1000	ns
t _{WHEH}	t _{CEH}	Write Enable High to Chip Enable High		0		ns
t _{WHGL}	t _{OEH}	Write Enable High to Output Enable Low		0		ns
t _{EHGL}	t _{OEH}	Chip Enable High to Output Enable Low		0		ns
t _{EHWH}	t _{WEH}	Chip Enable High to Write Enable High		0		ns
t _{WHDX}	t _{DH}	Write Enable High to Input Transition		0		ns
t _{EHDX}	t _{DH}	Chip Enable High to Input Transition		0		ns
t _{WHWL}	t _{WPH}	Write Enable High to Write Enable Low		50		ns
t _{WLWH}	t _{WP}	Write Enable Low to Write Enable High		100		ns
t _{WHWH}	t _{BLC}	Byte Load Repeat Cycle Time		0.2	100	μs
t _{WHRH}	t _{WC}	Write Cycle Time			3	ms
t _{WHRL}	t _{DB}	Write Enable High to Ready/Busy Low	Note 1		150	ns
t _{EHRL}	t _{DB}	Chip Enable High to Ready/Busy Low	Note 1		150	ns
t _{DVWH}	t _{DS}	Data Valid before Write Enable High		50		ns
t _{DVEH}	t _{DS}	Data Valid before Chip Enable High		50		ns

Note: 1. With a 3.3 kΩ external pull-up resistor.

Figure 10. Write Mode AC Waveforms - Write Enable Controlled

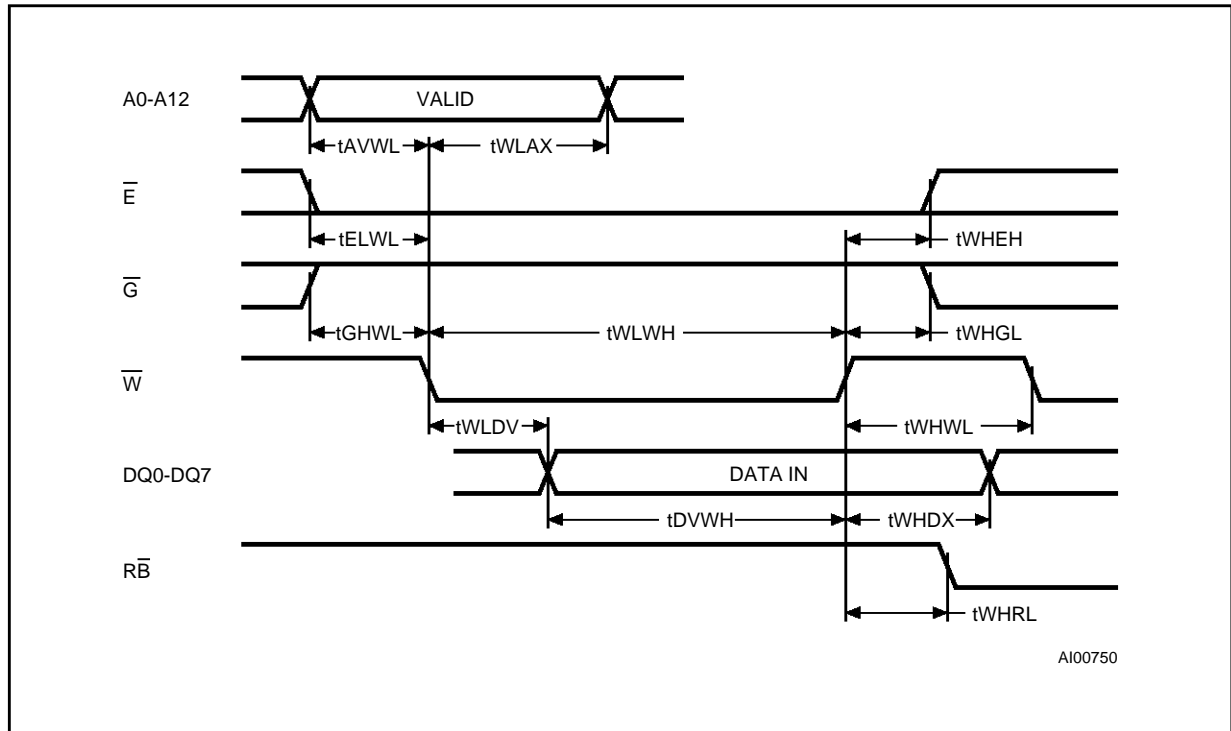

Figure 11. Write Mode AC Waveforms - Chip Enable Controlled

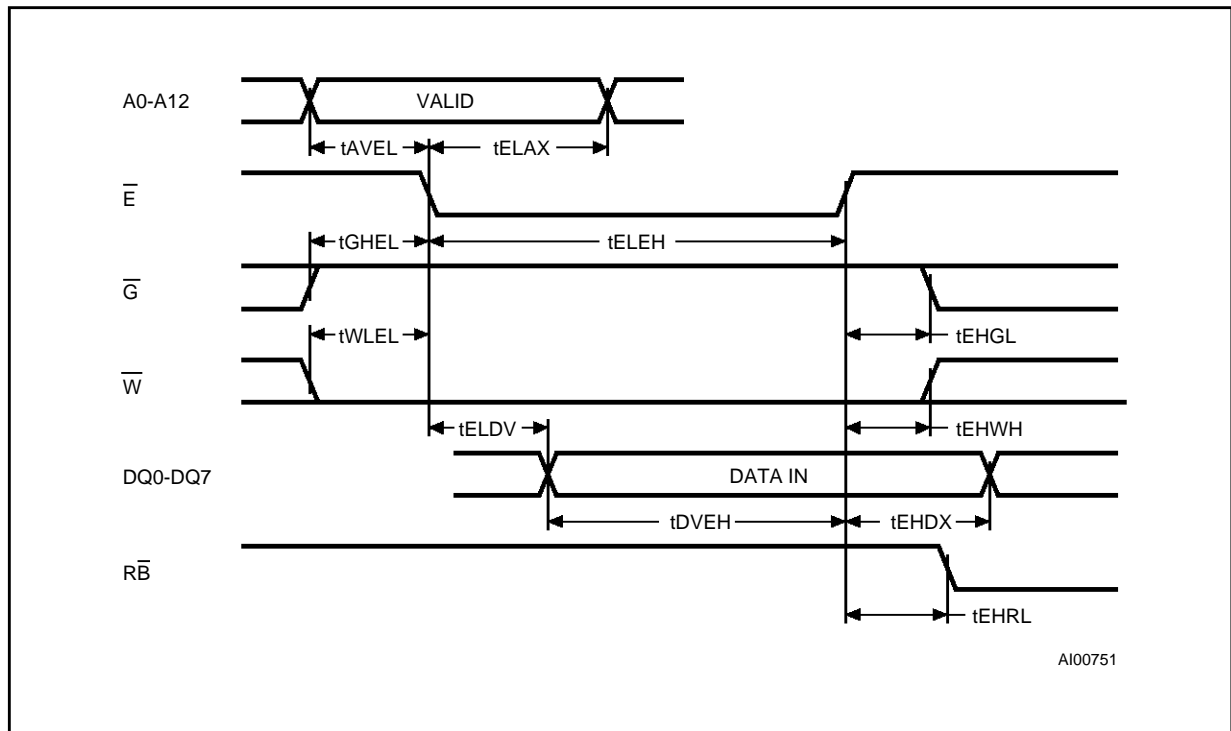

Figure 14. Data Polling Waveform Sequence

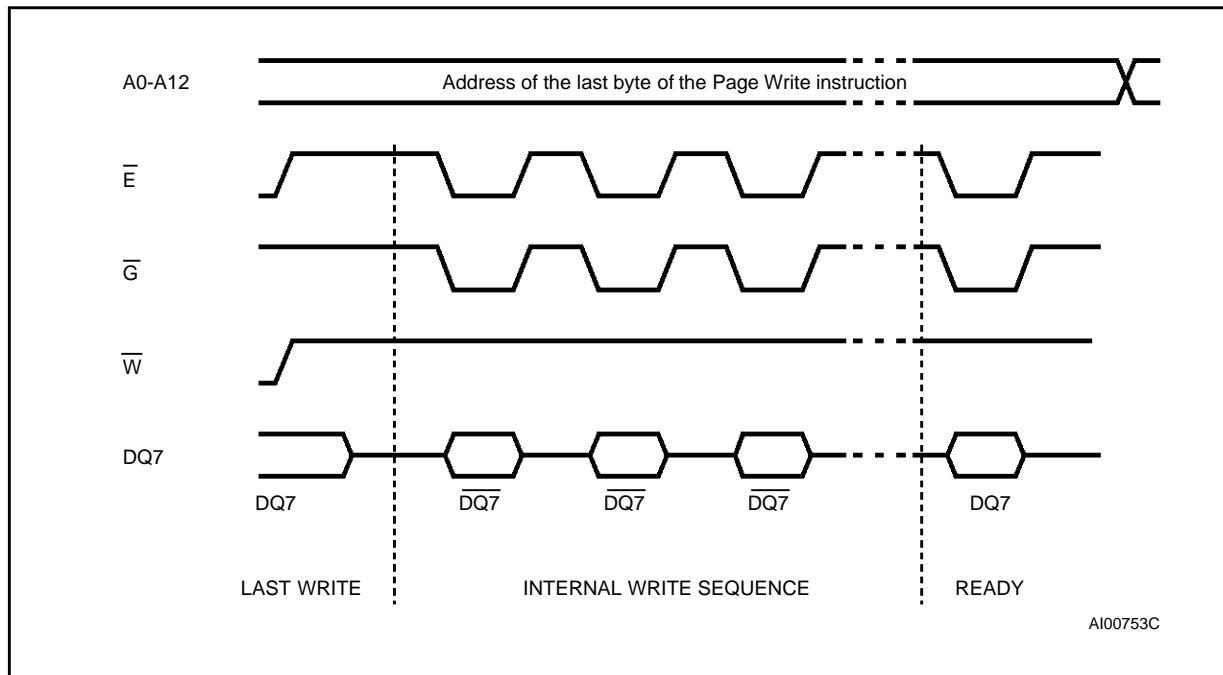
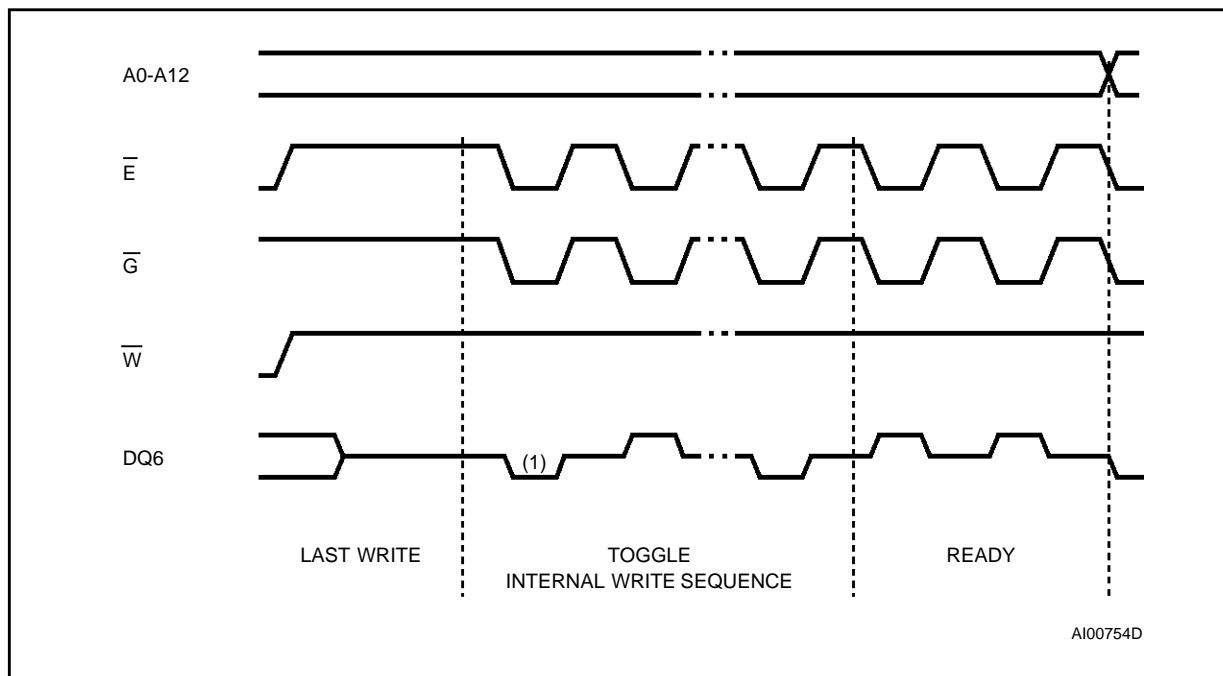
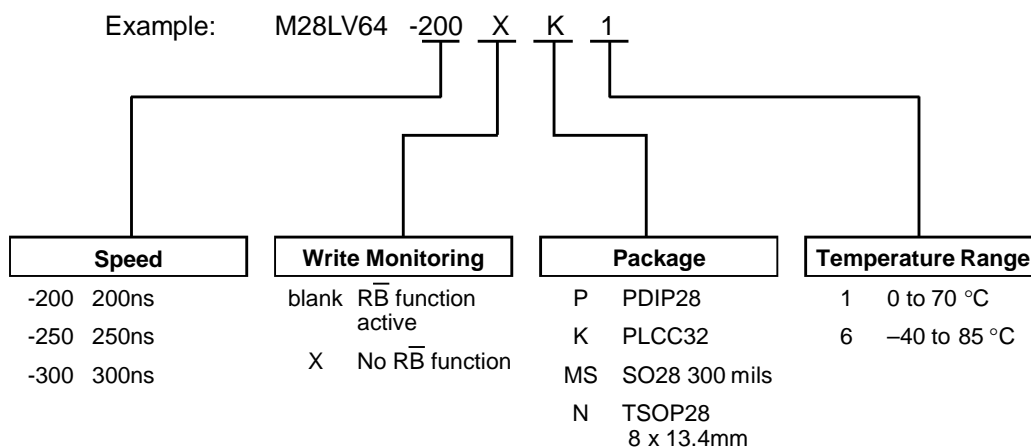

Figure 15. Toggle Bit Waveform Sequence



Note: 1. First Toggle bit is forced to '0'

ORDERING INFORMATION SCHEME



Parts are shipped with the memory content set at all "1's" (FFh).

For a list of available options (Speed, Package, Temperature Range, etc...) refer to the current Memory Shortform catalogue.

For further information on any aspect of this device, please contact the SGS-THOMSON Sales Office nearest to you.

PDIP28 - 28 pin Plastic DIP, 600 mils width

Symb	mm			inches		
	Typ	Min	Max	Typ	Min	Max
A		3.94	5.08		0.155	0.200
A1		0.38	1.78		0.015	0.070
A2		3.56	4.06		0.140	0.160
B		0.38	0.56		0.015	0.021
B1		1.14	1.78		0.045	0.070
C		0.20	0.30		0.008	0.012
D		34.70	37.34		1.366	1.470
E		14.80	16.26		0.583	0.640
E1		12.50	13.97		0.492	0.550
e1	2.54	–	–	0.100	–	–
eA		15.20	17.78		0.598	0.700
L		3.05	3.82		0.120	0.150
S		1.02	2.29		0.040	0.090
α		0°	15°		0°	15°
N		28			28	

PDIP28

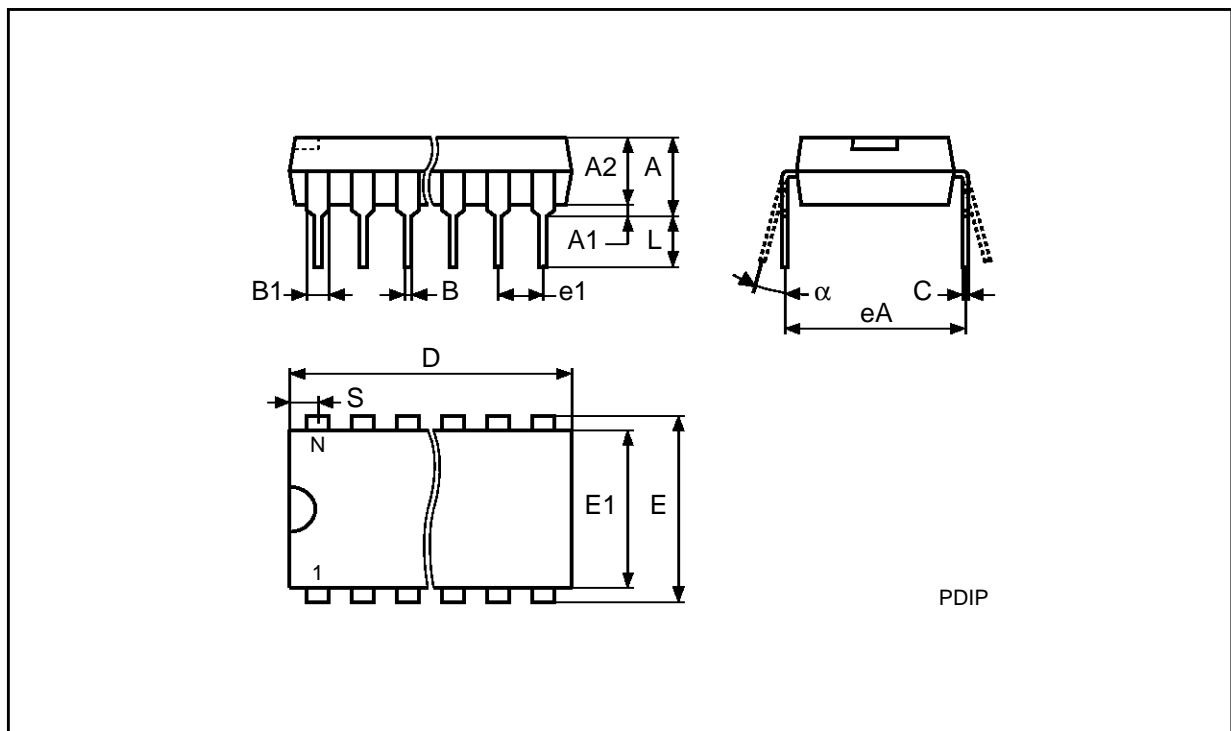

Drawing is not to scale.

PLCC32 - 32 lead Plastic Leaded Chip Carrier, rectangular

Symb	mm			inches		
	Typ	Min	Max	Typ	Min	Max
A		2.54	3.56		0.100	0.140
A1		1.52	2.41		0.060	0.095
B		0.33	0.53		0.013	0.021
B1		0.66	0.81		0.026	0.032
D		12.32	12.57		0.485	0.495
D1		11.35	11.56		0.447	0.455
D2		9.91	10.92		0.390	0.430
E		14.86	15.11		0.585	0.595
E1		13.89	14.10		0.547	0.555
E2		12.45	13.46		0.490	0.530
e	1.27	–	–	0.050	–	–
N		32			32	
Nd		7			7	
Ne		9			9	
CP			0.10			0.004

PLCC32

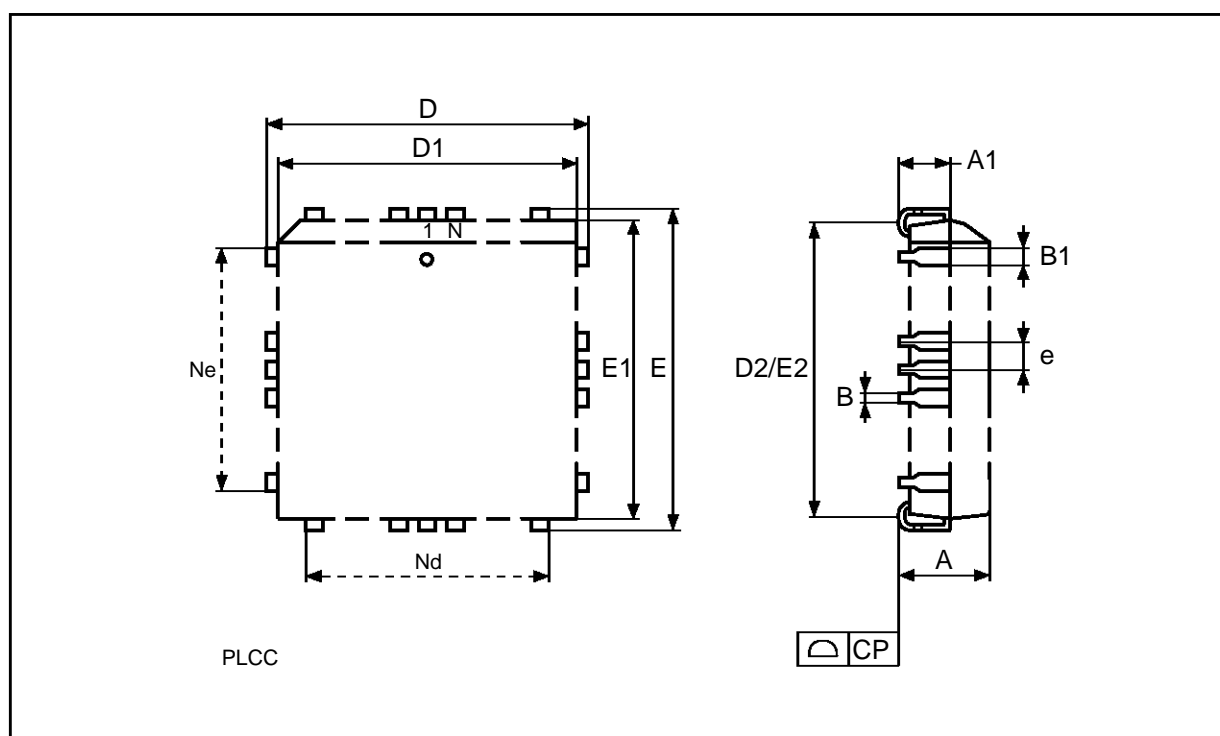

Drawing is not to scale.

SO28 - 28 lead Plastic Small Outline, 300 mils body width

Symb	mm			inches		
	Typ	Min	Max	Typ	Min	Max
A		2.46	2.64		0.097	0.104
A1		0.13	0.29		0.005	0.011
A2		2.29	2.39		0.090	0.094
B		0.35	0.48		0.014	0.019
C		0.23	0.32		0.009	0.013
D		17.81	18.06		0.701	0.711
E		7.42	7.59		0.292	0.299
e	1.27	-	-	0.050	-	-
H		10.16	10.41		0.400	0.410
L		0.61	1.02		0.024	0.040
α		0°	8°		0°	8°
N	28			28		
CP			0.10			0.004

SO28

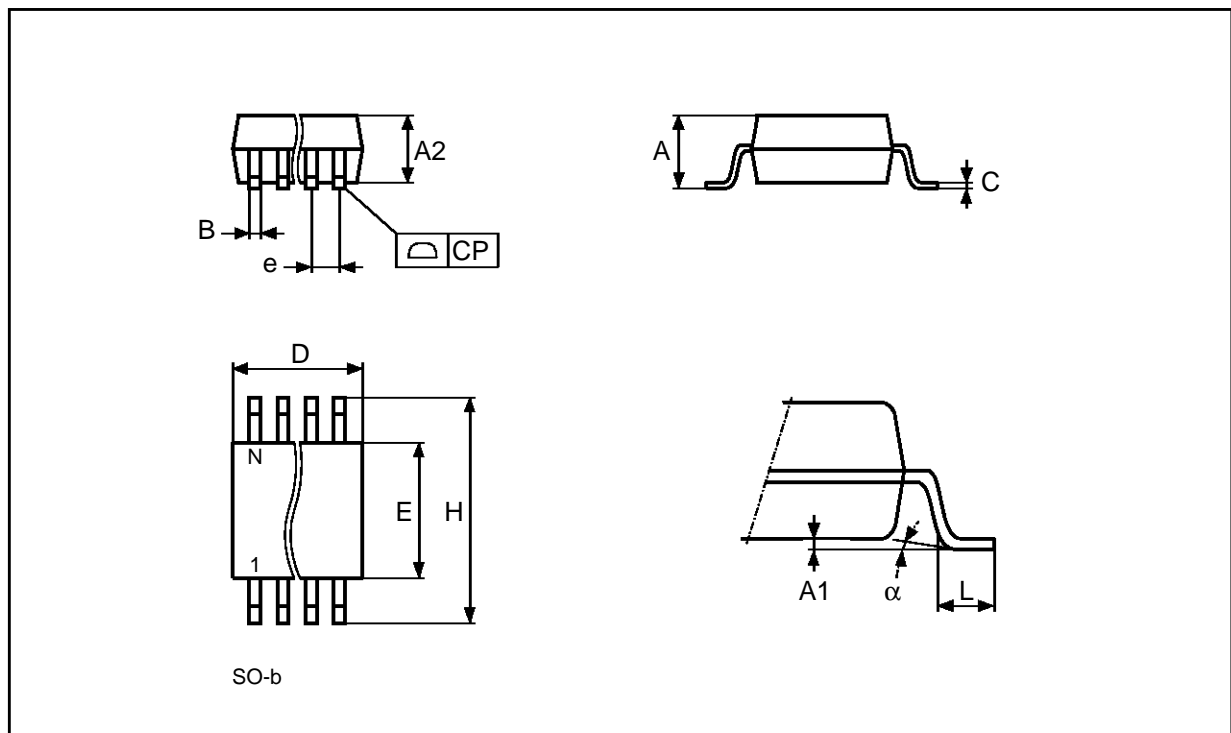

Drawing is not to scale.

TSOP28 - 28 lead Plastic Thin Small Outline, 8 x 13.4mm

Symb	mm			inches		
	Typ	Min	Max	Typ	Min	Max
A			1.25			0.049
A1			0.20			0.008
A2		0.95	1.15		0.037	0.045
B		0.17	0.27		0.007	0.011
C		0.10	0.21		0.004	0.008
D		13.20	13.60		0.520	0.535
D1		11.70	11.90		0.461	0.469
E		7.90	8.10		0.311	0.319
e	0.55	–	–	0.022	–	–
L		0.50	0.70		0.020	0.028
α		0°	5°		0°	5°
N	28			28		
CP			0.10			0.004

TSOP28

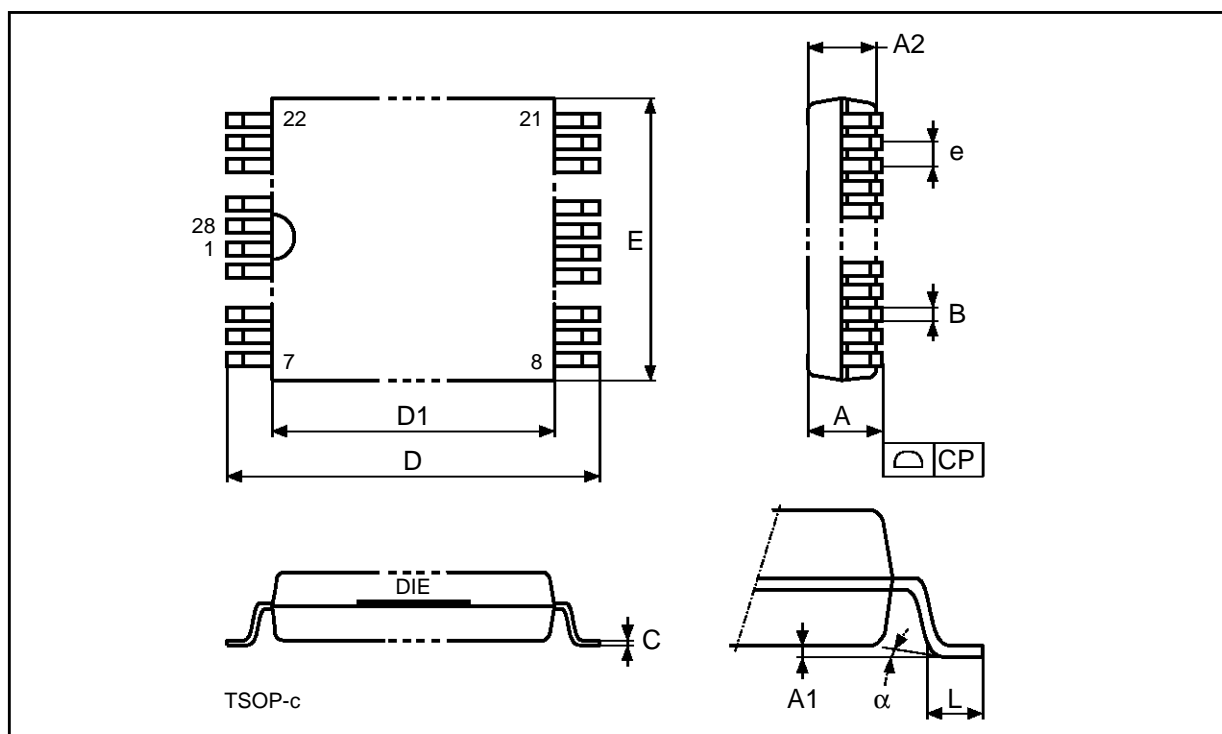

Drawing is not to scale.

Information furnished is believed to be accurate and reliable. However, SGS-THOMSON Microelectronics assumes no responsibility for the consequences of use of such information nor for any infringement of patents or other rights of third parties which may result from its use. No license is granted by implication or otherwise under any patent or patent rights of SGS-THOMSON Microelectronics. Specifications mentioned in this publication are subject to change without notice. This publication supersedes and replaces all information previously supplied. SGS-THOMSON Microelectronics products are not authorized for use as critical components in life support devices or systems without express written approval of SGS-THOMSON Microelectronics.

© 1996 SGS-THOMSON Microelectronics - All Rights Reserved

SGS-THOMSON Microelectronics GROUP OF COMPANIES
Australia - Brazil - Canada - China - France - Germany - Hong Kong - Italy - Japan - Korea - Malaysia - Malta - Morocco - The Netherlands -
Singapore - Spain - Sweden - Switzerland - Taiwan - Thailand - United Kingdom - U.S.A.